

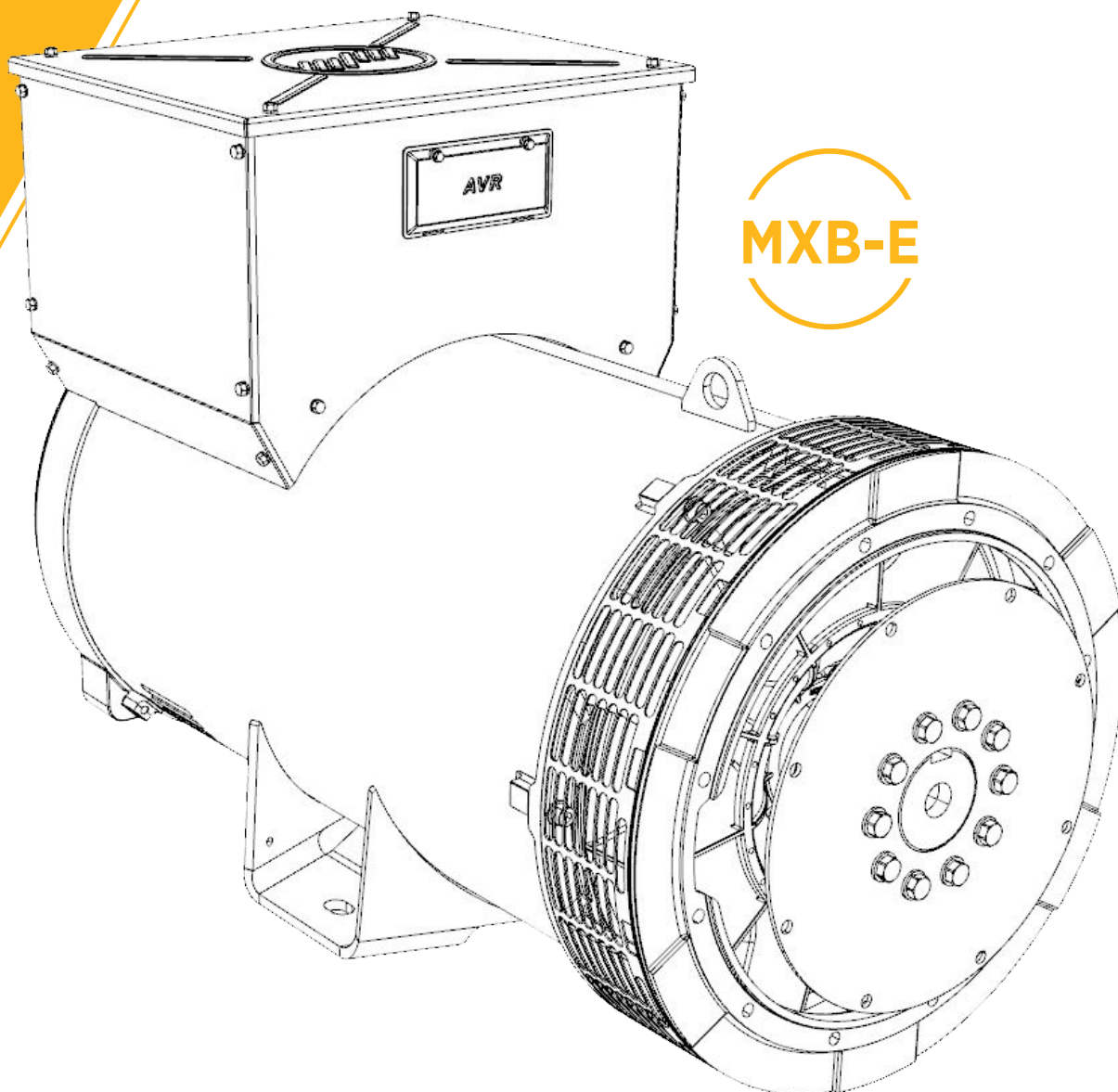

MarelliMotori
Powering the future

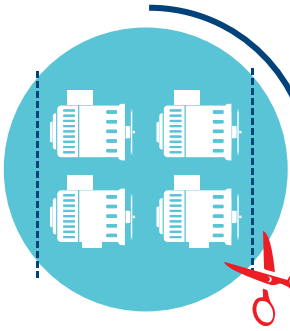

MXB-E



COMPACTNESS

Up to 22% length reduction on previous model
Canopy cost reduction

OPTIMIZED COST OF MANAGEMENT

Storage optimization
Reduced transportation cost

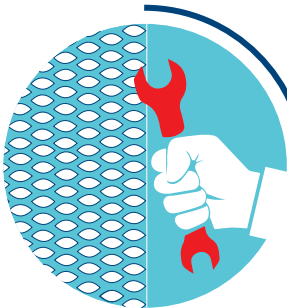

EASY MAINTENANCE

Filters can be removed easily
Wide openings allow fast maintenance operations

SAFETY FIRST

Protection from energized parts
No sharp edges



A RANGE INSPIRED BY OUR CUSTOMERS' NEEDS



FLEXIBLE DESIGN FOR INVENTORY MANAGEMENT

Customers can buy options separately and mount them according to their requirements

FLEXIBLE CABLE INTERFACE

Removable panels for easy drilling of cable outlet
Cable exit on 3 sides of terminal box
Easy dismantling of air grid
SAE adaptor with large openings for fast coupling

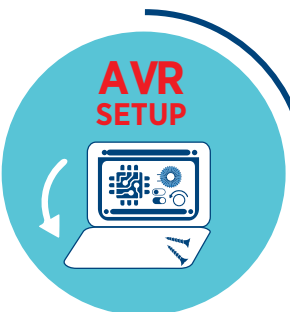
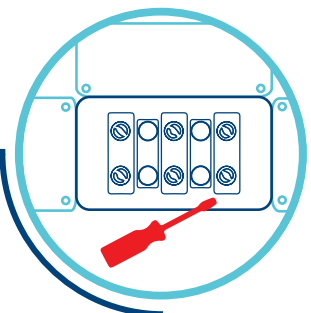

NEW AVR CONCEPT

Trimmers on the back of the AVR for external setting
Newly designed AVR mounted on dampers
AVR can be positioned on either lateral or front sides

RETROFITTING

Extra options available to satisfy industry requirements
PMG / Filters / H-eaters / Bearing PT100
Options can be mounted after delivery

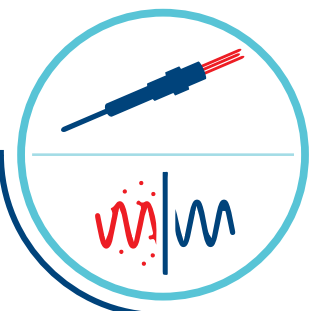

STANDARD CONFIGURATION

Main components	160	180	225	250				
Magnetic steel	Low losses. Insulated on both sides							
Housing	Fabricated steel							
N-End Endshield	Aluminum alloy			Cast iron				
Shaft	Carbon steel - hot rolled							
Fan	Plastic up to MXB-E 180 SC4 included - Aluminum alloy above							
Terminal board	Bakelite							
	7-pins		9-pins					
Construction	160	180	225	250				
Enclosure	Open Drip Proof							
Cooling system	IC01 as per IEC 60034-6							
Degree of protection	IP23 as per IEC 60034-5	IP23 as per IEC 60034-5 (up to IP 44)						
Mounting	Horizontal single bearing	Horizontal single bearing - IM 2105 (double bearing available on request)						
Technical data	160	180	225	250				
Insulation system	Class H for stator and rotor							
Impregnation	Epoxy resin through high quality process.							
Winding pitch	2/3							
Bearing data	160	180	225	250				
Bearing type	D-End	N-End	D-End	N-End	D-End	N-End	D-End	N-End
	n/a	6207-2RS1-C3	6311-2RS1-C3-LTH23	6207-2RS1-C3	6215-2RS1-C3-WT	6309-2RS1-C3* *single bearing 6309-2RS1-C3-WT	6218-C3	6313-2Z-C3
	Permanently greased							
Bearing lifetime	≥ 20.000 hours							
Operation at reduced speed	All regulators work to reduce the excitation current in order to protect the excitation system when the generator is used at reduced speed							
Excitation system	160	180	225	250				
Excitation type	Brushless with rotating rectifier (Graetz 6-Diode bridge)							
PMG	Optional							
Auxiliary winding	Optional							
Applicable standards	160	180	225	250				
Standards	IEC 60034-1; BS 4999-5000; NEMA MG 1.32							
Certifications	UL 1004-1, UL 1004-4, C22.2 No. 100 (Certification pending)							
AVR	160	180	225	250				
AVR model	AVR code: 11000013 - M00FA122A / AVR model: MARK VX. Dedicated AVR for optional PMG.							
AVR position	On left side viewed from D-end		Front mounted					
AVR supply	Mains							
Voltage sensing	Single phase							
Accuracy	± 0,5% (@ rated load, balanced and non-distorting, P.F. 0,8)							
EMI filter	Included							
Limiters	U/F Under Frequency							
Three phase short circuit current	Generators with auxiliary windings or PMG ensure a three phase short-circuit current (I _{cc}) higher than 3 times the rated current (I _n): I _{cc} > 3 I _n for 10 seconds							
Operating conditions	160	180	225	250				
Overload during S1 continuous duty	10% for 1 hour / 15% for 10 minutes / 30% for 4 minutes / 50% for 2 minutes							
Air inlet	Axial and radial							
Damper cage	Rotor is provided with large sized damper cage							
Radio interference	Class B Group 1 as EN 55011							
THD / THF	Typically THD < 2% at no load / THF < 2%							
Parallel operations	All generators are provided with an amply sized damper cage and are suitable for parallel operations with other generators, when equipped with the paralleling unit (available on 180,225 and 250 frame size)							
Winding treatment	Standard winding impregnation for non-aggressive environment with relative humidity ≤ 95% Special treatment on windings for aggressive environment and relative humidity higher than 95% on request.							

ALTITUDE

The rated outputs refer to installation up to 1.000 m a.s.l. Above this level the following derating factors must be applied.

Altitude (m asl)	< 1.000	< 1.500	< 2.000	< 2.500	< 3.000
K factor	1,00	0,96	0,93	0,90	0,86

AMBIENT TEMPERATURE

The rated outputs given in this catalogue are based on a maximum ambient temperature of 40°C.

When operating at different ambient temperatures the output rating can be obtained by applying the factors as in the following table.

Ambient temperature (°C)	30	35	40	45	50	55
K factor	1,04	1,00	1,00	0,96	0,93	0,9

POWER FACTOR

The nominal power factor is 0,8 lagging. For different power factor values the following derating factors must be applied.

Power factor	1,0	0,8	0,7	0,6	0,5	0,3	0
K factor	1,00	1,00	0,93	0,88	0,84	0,82	0,80

The rated outputs refer to IP23 protection degree with no filters. When filters are mounted, the following derating factors must be applied.

Configuration	Inlet filter	Inlet + outlet filter (IP43)	Inlet + outlet filter (IP44)
K factor	0,95	0,92	0,90

VOLTAGE AND FREQUENCY

Generators can operate at 50 Hz and 60 Hz with below voltage values. Other voltages are possible with optional adapted windings.

Connection	50 Hz	60 Hz
Series star	380V - 440V	380V - 480V
Parallel star	190V - 220V	190V - 240V
Series delta	220V - 254V	220V - 277V

Technical data may be subject to change to update or improve products, without prior notice.

OPTIONS AVAILABLE

	160	180	225	250
Operating conditions				
Special voltage	o	o	o	o
Provision for parallel operation with similar generators with AVR (MEC 20)	n/a	o*	o	o
Terminal box				
IP55 terminal box	o	o	o	o ⁽¹⁾
Large terminal box	n/a	o	n/a	n/a
Separate auxiliary terminal box	n/a	o	o	o
Non-magnetic exit cable panel	n/a	n/a	n/a	o
6-leads winding	n/a	n/a	n/a	o
Heatings				
Anti-condensation heaters (V=220 V)	o	o	o	o
Temperature sensors				
N. 3 PTC thermistors	o	o	o	o
N. 3 PT100 resistance temperature detectors in stator winding	n/a	o	o	o
N. 1 PT100 on N-end bearing	o	o	o	o
N. 1 PT100 on D-end bearing (for double bearing configuration)	n/a	o	o	o
N. PT100 duplex type on N-End bearing	n/a	o	o	o
N. PT100 duplex type on D-End bearing (for double bearing configuration)	n/a	o	o	o
Protection degree				
Inlet filter	n/a	o	o	o
Inlet + outlet filter (IP43)	n/a	o	o	o
Inlet + outlet filter (IP44)	n/a	o	o	o
AVR				
Single-phase sensing AVR (Mark VX), side mounted	s	s	o	o
Single-phase sensing AVR (Mark VX), front mounted	n/a	o*	s	s
Three-phase sensing AVR (MEC-20), side mounted	n/a	o*	o	o
Three-phase sensing AVR (MEC-20), front mounted	n/a	o*	n/a	o
Digital AVR D-Vo (mounted on board)	n/a	n/a	n/a	o
Automatic power factor regulator (mounted on board)	n/a	n/a	n/a	o
Painting				
Special painting cycle (MM ref. F96831)	o	o	o	o
Painting colour different from RAL 9005 and RAL 5010	o	o	o	o
Painting colour RAL 9005 Black or RAL 5010 Blue (standard alternator not painted)	o	o	o	o
Special painting cycle (MM ref. F96819)	o	o	o	o
Special painting cycle (MM ref. F96826)	o	o	o	o
Environmental solutions				
Tropicalization (CW1081)	o	o	o	o
Excitation system				
Auxiliary winding	o	o	o	o
PMG with single-phase AVR (Mark XX) side mounted	o	o	o	n/a
PMG with single-phase AVR (Mark XX) front mounted	n/a	o*	o	n/a
PMG with three-phase AVR (MEC-20) side mounted	n/a	o*	o	o
PMG with three-phase AVR (MEC-20) front mounted	n/a	o*	n/a	o
PMG with digital AVR D-Vo (mounted on board)	n/a	n/a	n/a	o
Mechanical configuration				
Special shaft extension	n/a	n/a	n/a	o
Second shaft extension (as per catalogue)	n/a	n/a	n/a	o
Special housing ⁽²⁾	n/a	o	o	o
NDE grease nipple	n/a	n/a	n/a	o
DE grease nipple	n/a	n/a	n/a	o
Other accessories				
N. 3 CT single core on neutral point (low voltage)	n/a	n/a	n/a	o
* This option includes also large terminal box.				
⁽¹⁾ On H class overtemperature a 10% derating must be applied.	o: optional n/a: not available s: standard			
⁽²⁾ Based on volumes.				

TECHNICAL DATA

4 POLES - 400 V - 50 Hz							1500 rpm	
Type	Continuous duty rating (kVA)			Stand by kVA		Single Phase 230 V	Efficiency	Weight
	125/40 ΔT Cl, H	105/40 ΔT Cl, F	80/40 ΔT Cl, B	163/27	150/40	Derating factor Zig-zag	P.F, 0,8 4/4 LOAD	Kg
MXB-E 160 XA4	10.0	9.2	8.0	11.0	10.5	0.66	79.0	83
MXB-E 160 SA4	12.5	11.5	10.0	13.8	13.1	0.66	80.0	88
MXB-E 160 MX4	15.0	13.7	12.0	16.5	15.8	0.66	83.0	97
MXB-E 160 MA4	17.5	16.0	14.0	19.3	18.4	0.66	82.7	102
MXB-E 160 LA4	20.0	18.3	16.0	22.0	21.0	0.66	85.4	116
MXB-E 180 XS4	25.0	22.9	20.0	27.5	26.3	0.66	85.2	125
MXB-E 180 XB4	30.0	27.5	24.0	33.0	31.5	0.66	87.0	137
MXB-E 180 SB4	34.0	31.2	27.2	37.4	35.7	0.58	87.0	145
MXB-E 180 SC4	40.0	36.7	32.0	44.0	42.0	0.56	88.0	156
MXB-E 180 MA4	45.0	41.2	36.0	49.5	47.3	0.58	88.9	181
MXB-E 180 MC4	50.0	45.8	40.0	55.0	52.5	0.55	89.3	189
MXB-E 180 LB4	65.0	59.6	52.0	71.5	68.3	0.53	90.0	234
MXB-E 225 XA4	70	64	56	77	74	0.55	88.3	280
MXB-E 225 XB4	80	73	64	88	84	0.55	88.9	296
MXB-E 225 SB4	100	92	80	110	105	0.51	90.4	335
MXB-E 225 MA4	120	110	96	132	126	0.50	91.0	377
MXB-E 225 MB4	135	124	108	149	142	0.53	92.0	407
MXB-E 225 LA4	150	137	120	165	158	0.50	91.9	434
MXB-E 225 LB4	165	151	132	182	173	0.49	92.4	471
MXB-E 250 SA4	180	165	144	198	189	0.55	91.8	513
MXB-E 250 SB4	200	183	160	220	210	0.55	92.0	541
MXB-E 250 MA4	230	211	184	253	242	0.55	92.2	599
MXB-E 250 MB4	250	229	200	275	263	0.55	92.8	652
MXB-E 250 LA4	275	252	220	302	289	0.50	93.0	780
MXB-E 250 LB4	300	275	240	330	315	0.50	93.4	783

Technical data may be subject to change to update or improve products, without prior notice.

TECHNICAL DATA

4 POLES - 480 V - 60 Hz							1800 rpm	
Type	Continuous duty rating (kVA)			Stand by kVA		Single Phase 230 V	Efficiency	Weight Kg
	125/40 ΔT Cl, H	105/40 ΔT Cl, F	80/40 ΔT Cl, B	163/27	150/40	Derating factor Zig-zag	P.F. 0,8 4/4 LOAD	
								%
MXB-E 160 XA4	12.5	11.5	10.0	13.8	13.1	0.66	81.1	83
MXB-E 160 SA4	15.6	14.3	12.5	17.2	16.4	0.66	81.9	88
MXB-E 160 MX4	18.8	17.2	15.0	20.6	19.7	0.66	84.5	97
MXB-E 160 MA4	21.9	20.0	17.5	24.1	23.0	0.66	84.3	102
MXB-E 160 LA4	25.0	22.9	20.0	27.5	26.3	0.66	86.8	116
MXB-E 180 XS4	31.3	28.6	25.0	34.4	32.8	0.66	86.7	125
MXB-E 180 XB4	37.5	34.4	30.0	41.3	39.4	0.66	88.2	137
MXB-E 180 SB4	42.5	39.0	34.0	46.8	44.6	0.58	88.3	145
MXB-E 180 SC4	50.0	45.8	40.0	55.0	52.5	0.56	89.2	156
MXB-E 180 MA4	56.3	51.6	45.0	61.9	59.1	0.58	89.9	181
MXB-E 180 MC4	62.5	57.3	50.0	68.8	65.6	0.55	90.3	189
MXB-E 180 LB4	81.3	74.5	65.0	89.4	85.3	0.53	90.8	234
MXB-E 225 XA4	88	80	70	96	92	0.55	89.0	280
MXB-E 225 XB4	100	92	80	110	105	0.55	89.8	296
MXB-E 225 SB4	125	115	100	138	131	0.51	91.2	335
MXB-E 225 MA4	150	137	120	165	158	0.50	91.8	377
MXB-E 225 MB4	169	155	135	186	177	0.53	92.4	407
MXB-E 225 LA4	188	172	150	206	197	0.50	92.6	434
MXB-E 225 LB4	206	189	165	227	217	0.49	93.1	471
MXB-E 250 SA4	225	206	180	248	236	0.55	92.4	513
MXB-E 250 SB4	250	229	200	275	263	0.55	92.7	541
MXB-E 250 MA4	288	263	230	316	302	0.55	92.9	599
MXB-E 250 MB4	313	286	250	344	328	0.55	93.4	652
MXB-E 250 LA4	344	315	275	378	361	0.50	93.5	780
MXB-E 250 LB4	375	344	300	413	394	0.50	93.9	783

Technical data may be subject to change to update or improve products, without prior notice.

DIMENSIONS

MXB-E 160 - single bearing

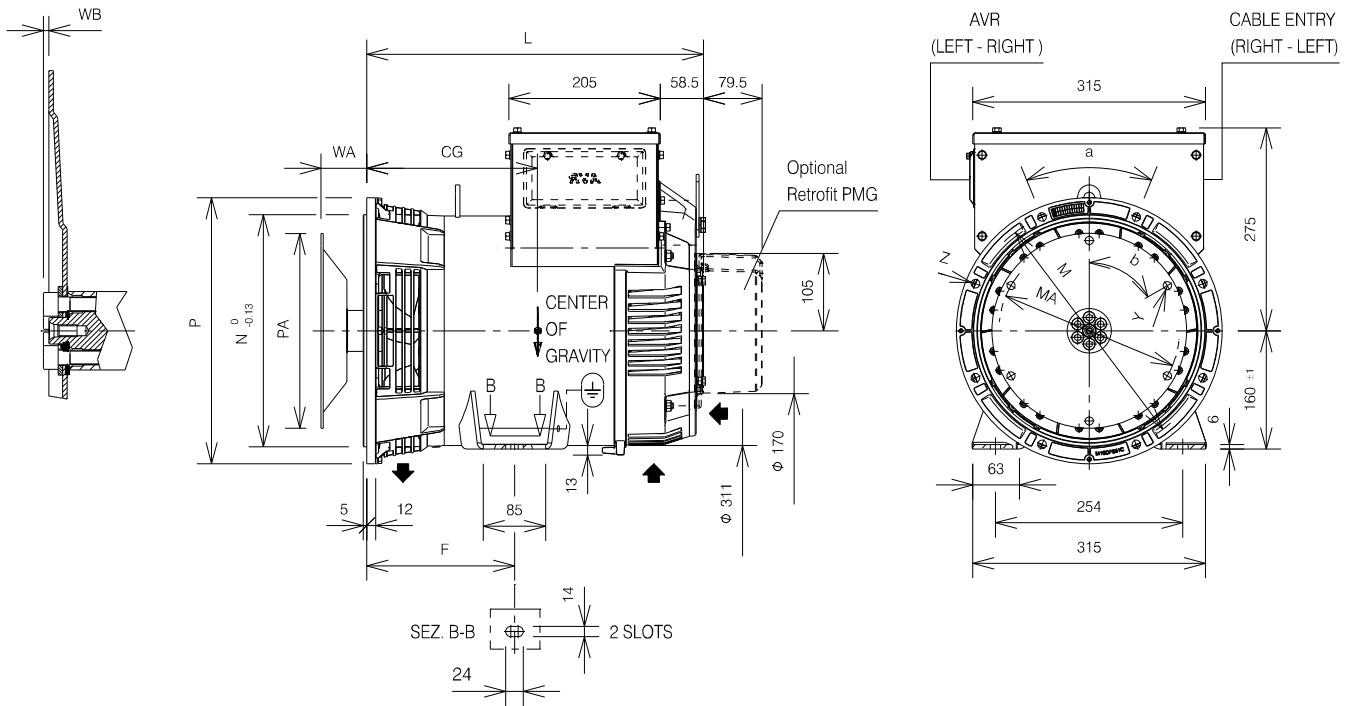

Type	Dimensions [mm]		
MXB-E	L	F	CG
			SAE 3-SAE 4-SAE 5
MXB-E 160 XA	416	200	198
MXB-E 160 SA			202
MXB-E 160 MX	441		208
MXB-E 160 MA			210
MXB-E 160 LA	456		223

Connections			
COUPLING	FLANGE		
	SAE J617		
SAE J620	5	4	3
6 1/2	•		
7 1/2	○	•	
8	•	•	•
10		•	•
11 1/2			•

• Available ○ Most common

Dimensions [mm]													
FLANGE						COUPLING							
SAE J617	N	P	Z		a	SAE J620	PA	MA	Y		b	WA	WB
			NR	Ø					NR	Ø			
5	314,32	360	8	11,5	45°	6 1/2	215,9	200	6	9	60°	30,2	13
4	361,95	407	12	11,5	30°	7 1/2	241,3	222,3	8	9	45°	30,2	13
3	409,58	455	12	11,5	30°	8	263,52	244,48	6	11	60°	62	-
						10	314,3	295,3	8	11	45°	53,8	13
						11 1/2	352,4	333,4	8	11	45°	39,6	13

DIMENSIONS

MXB-E 180 - single bearing

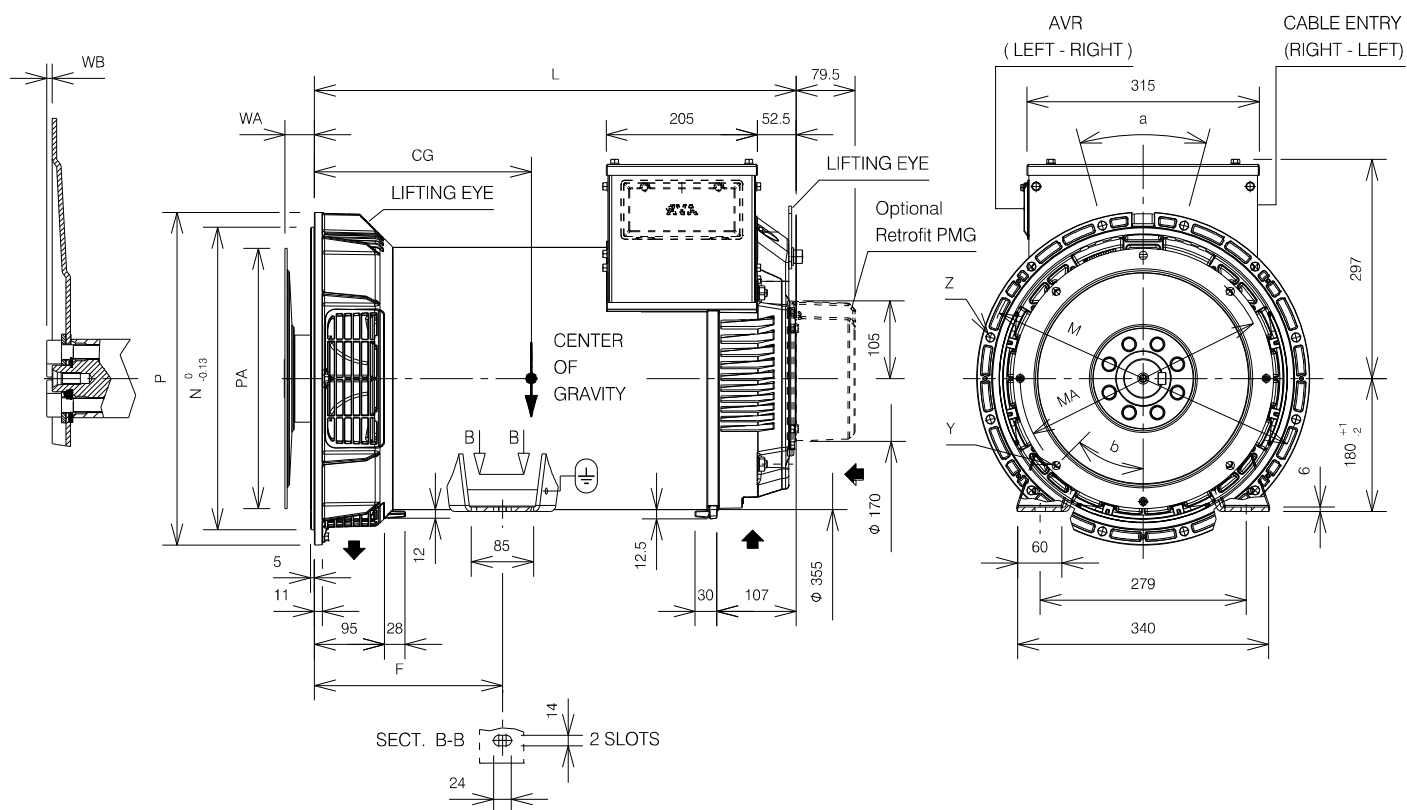

Type	Dimensions [mm]			
	L	F	CG	
			SAE 4-SAE 5	SAE 2-SAE 3
MXB-E 180 XS	496	205	205	210
MXB-E 180 XB			217	222
MXB-E 180 SB			233	238
MXB-E 180 SC			245	250
MXB-E 180 MA	546	255	250	254
MXB-E 180 MC			260	264
MXB-E 180 LB			314	319

Connections				
COUPLING	FLANGE			
	SAE J617			
	5 ^(*)	4	3	2
SAE J620				
6 1/2	•			
7 1/2	•	•		
8	•	•	•	•
10		•	•	•
11 1/2			○	•

• Available ○ Most common
 (*) Not available for frame size MA4, MC4 and LB4

Dimensions [mm]														
FLANGE							COUPLING							
SAE J617	N	P	M	Z		a	SAE J620	PA	MA	Y		b	WA	WB
				NR	Ø					NR	Ø			
5	314,32	355,6	333,38	8	11	45°	6 1/2	215,90	200,02	6	9	60°	30,2	13
4	361,95	403,4	381,00	12	11	30°	7 1/2	241,30	222,25	8	9	45°	30,2	13
3	409,58	450,8	428,62	12	11	30°	8	263,52	244,48	6	11	60°	62,0	-
2	447,68	489,0	466,72	12	11	30°	10	314,32	295,28	8	11	45°	53,8	13
							11 1/2	352,42	333,38	8	11	45°	39,6	13

DIMENSIONS

MXB-E 225 - single bearing

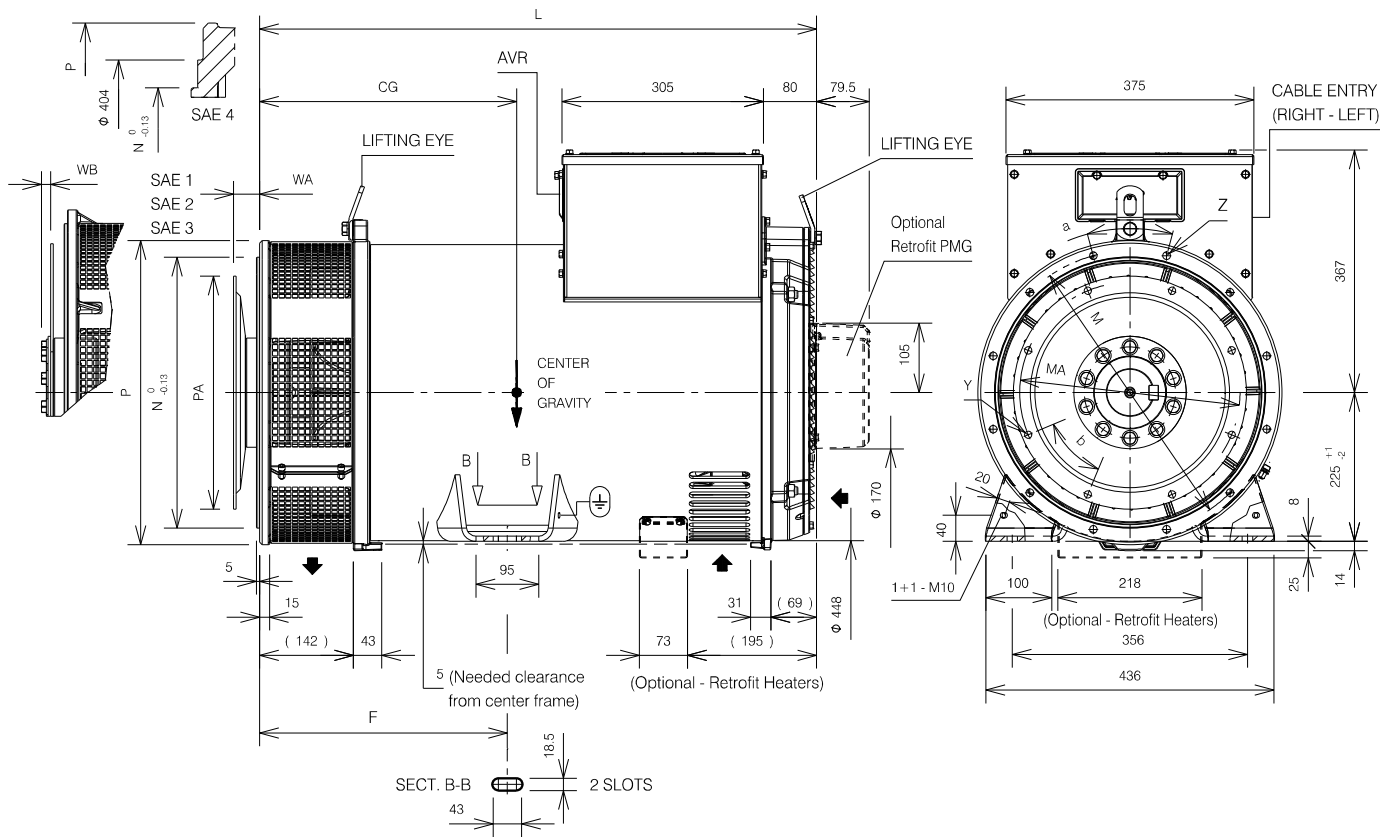

Type	Dimensions [mm]			
	L	F	CG SAE4-SAE3	CG SAE2-SAE1
MXB-E 225 XA	708	325	325	312
MXB-E 225 XB			329	317
MXB-E 225 SB			352	348
MXB-E 225 MA	778	375	344	331
MXB-E 225 MB			386	372
MXB-E 225 LA	843	375	389	377
MXB-E 225 LB			436	423

Connections				
COUPLING	FLANGE			
	SAE J617			
SAE J620	4	3	2	1
10	●	●		
11 1/2		○	●	●
14				●
● Available ○ Most common				

Dimensions [mm]														
FLANGE							COUPLING							
SAE J617	N	P	M	Z		a	SAE J620	PA	MA	Y		b	WA	WB
				NR	Ø					NR	Ø			
4	361,95	460	381,00	12	11	30°	10	314,32	295,28	8	11	45°	53,8	-
3	409,58	460	428,62	12	11	30°	11 1/2	352,42	333,38	8	11	45°	39,6	-
2	447,68	495	466,72	12	11	30°	14	466,72	438,15	8	14	45°	25,4	14
1	511,18	552,5	530,22	12	11	30°								

Technical data may be subject to change to update or improve products, without prior notice.

DIMENSIONS

MXB-E 250 - single bearing

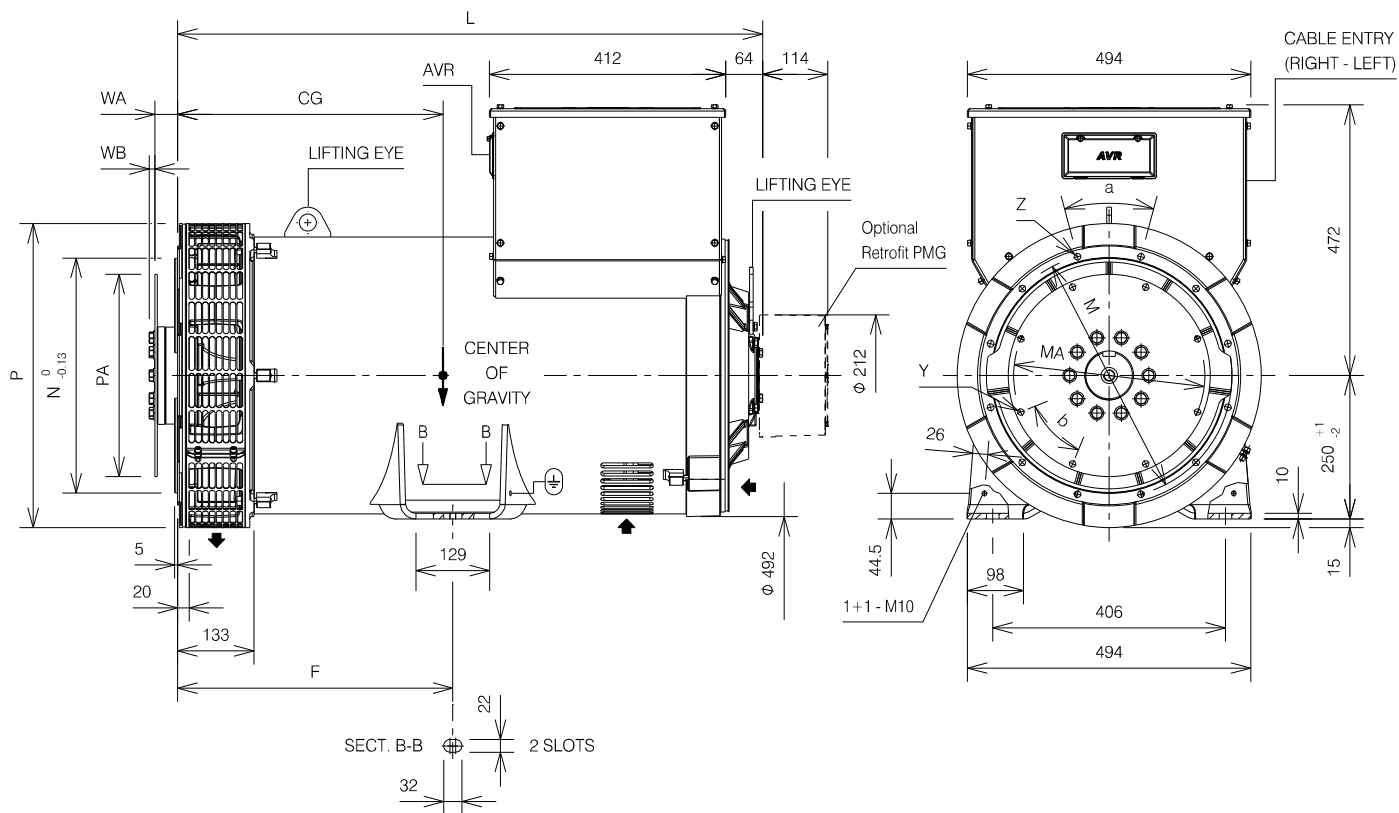

Type	Dimensions [mm]		
	L	F	CG
MXB-E 250 SA	800	345	370
MXB-E 250 SB			380
MXB-E 250 MA	910	425	415
MXB-E 250 MB			430
MXB-E 250 LA	1020	480	485
MXB-E 250 LB			

Connections			
COUPLING	FLANGE		
SAE J620	SAE J617		
	3	2	1
11 1/2	○	●	●
14			●
● Available		○ Most common	

Dimensions [mm]														
FLANGE							COUPLING							
SAE J617	N	P	M	Z		a	SAE J620	PA	MA	Y		b	WA	WB
				No	DIA					No	DIA			
3	409.58	530	428.62	12	11.5	30°	11 1/2	325.42	333.38	8	11	45°	39.6	10
2	447.68	530	466.72	12	11.5	30°	14	466.72	438.15	8	14	45°	25.4	10
1	511.18	552	530.22	12	11.5	30°								

Technical data may be subject to change to update or improve products, without prior notice.

CONTACTS

Italy HQ

Marelli Motori S.p.A.

Via Sabbionara 1
36071 Arzignano (VI) - Italy
(T) +39 0444 479 711
(F) +39 0444 479 888
info@marellimotori.com

USA

Marelli USA, Inc.

2200 Norcross Parkway, Suite 290
Norcross, GA 30071 - United States
(T) +1 859 734 2588
(F) +1 859 734 0629
usa@marellimotori.com

South Africa

Marelli Motori South Africa (Pty) Ltd

Unit 2, corner Director & Megawatt Road
Spartan Ext. 23
Kempton Park 1619 Gauteng
Republic of South Africa
(T) +27 11 392 1920
(F) +27 11 392 1668
southafrica@marellimotori.com

Spain

Representative Office

08195 Sant Cugat
Barcelona - Spain
(T) +34 664 464 121
spain@marellimotori.com

Vietnam

Representative Office

Level 46 Bitexco Financial Tower
No.2 Hai Trieu Street - District 1
Ho Chi Minh City - Vietnam
(T) +84 28 6287 6099
vietnam@marellimotori.com

Asia Pacific

Marelli Motori Asia Sdn Bhd

Lot 1-8, Persiaran Jubli Perak,
Seksyen 22, 40300 Shah Alam,
Selangor D.E. - Malaysia
(T) +60 355 171 999
(F) +60 355 171 883
malaysia@marellimotori.com

Central Europe

Marelli Motori Central Europe GmbH

Heilswannenweg 50
31008 Elze - Germany
(T) +49 5068 462 400
(F) +49 5068 462 409
germany@marellimotori.com

Middle East

Marelli Motori Middle East

4403 - 18, 44th Floor, BB2
Mazaya Business Avenue
Jumeirah Lake Towers
Dubai - UAE
(T) +971 4 426 4263
(F) +971 4 362 4345
uae@marellimotori.com

United Kingdom

Marelli UK

Kirkby Lane, Pinxton
Nottinghamshire - NG16 6HX
United Kingdom
(T) +44 79 3050 6301
uk@marellimotori.com

Russia

614007, Perm, 25 October,
building 72, office 40
(T) +7 (342) 262-85-56
sales@marellimotori.ru

